

**SHUT IT™****BADASS****NEW**

Shut It™ VersaWeld Gate Hinge

Weld directly to square or round post. Powder Coat out of the box

New VersaWeld gate hinges can be welded to flat or round surfaces. Manufactured with exclusive maintenance-free high-temperature sealed bearings, safe to powder coat with hinges installed on gate.

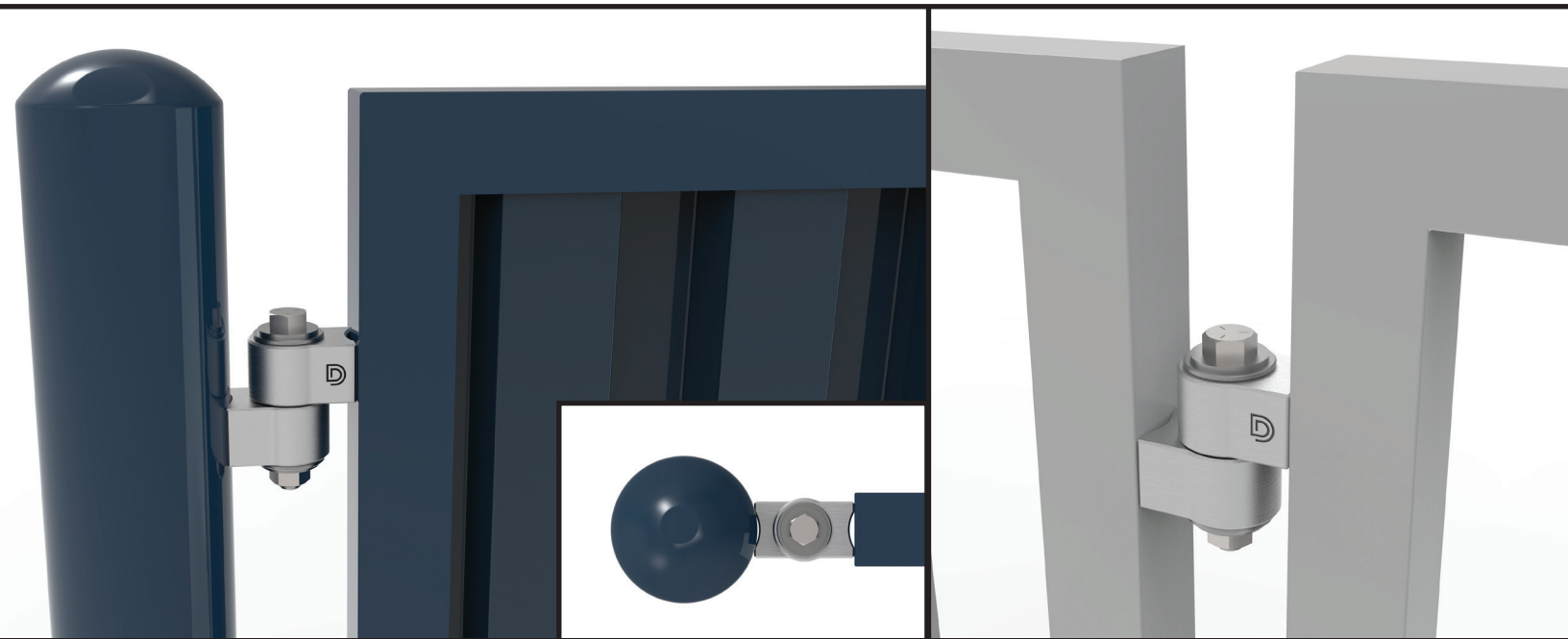

VersaWeld Gate Hinge

- Post and hinge side bodies are built to weld to flat or round surfaces without utilizing adaptors
- Clean, good looking welds result from not applying an angle iron adaptor for round surfaces
- Safe to powder coat with hinges installed on gate
- High-temperature sealed bearings require no greasing – no maintenance. EVER!
- Precision bushing distributes gate load for optimal performance and hinge longevity
- Zinc electroplating for long lasting rust and corrosion protection
- Maximum gate weight of 1,100 lb (500kg)
- Tested to 1 Million Open / Close Cycles
- Limited Lifetime Warranty

Code	Product Name	Gate Gap	Finish	# of Sealed Bearings	Max Gate Weight	Max Gate	Yoke Material	Body Material	Height	Weight
CI3075	VersaWeld BadAss	Flat Posts 2.75" (70mm) (not adjustable) Round Posts approx. 0 Gap	Zinc	2	1,100 lb (500kg)	2,000 lb (900kg)	Steel	Steel	3.75" (95mm)	2.2 lb (1.0kg)

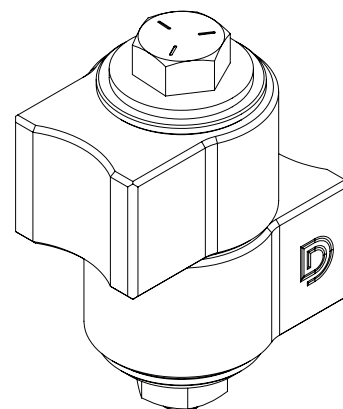
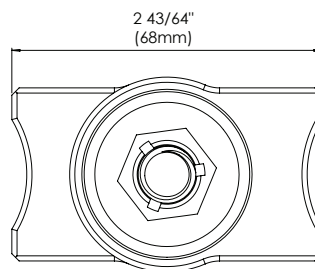
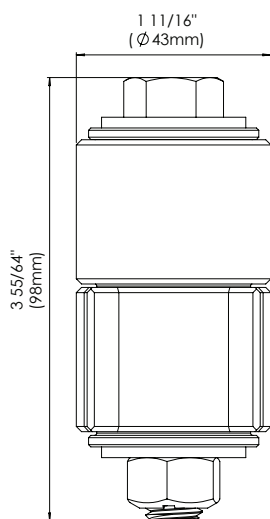
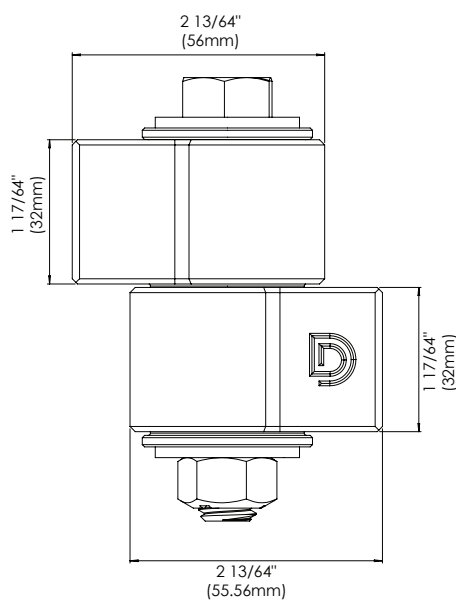
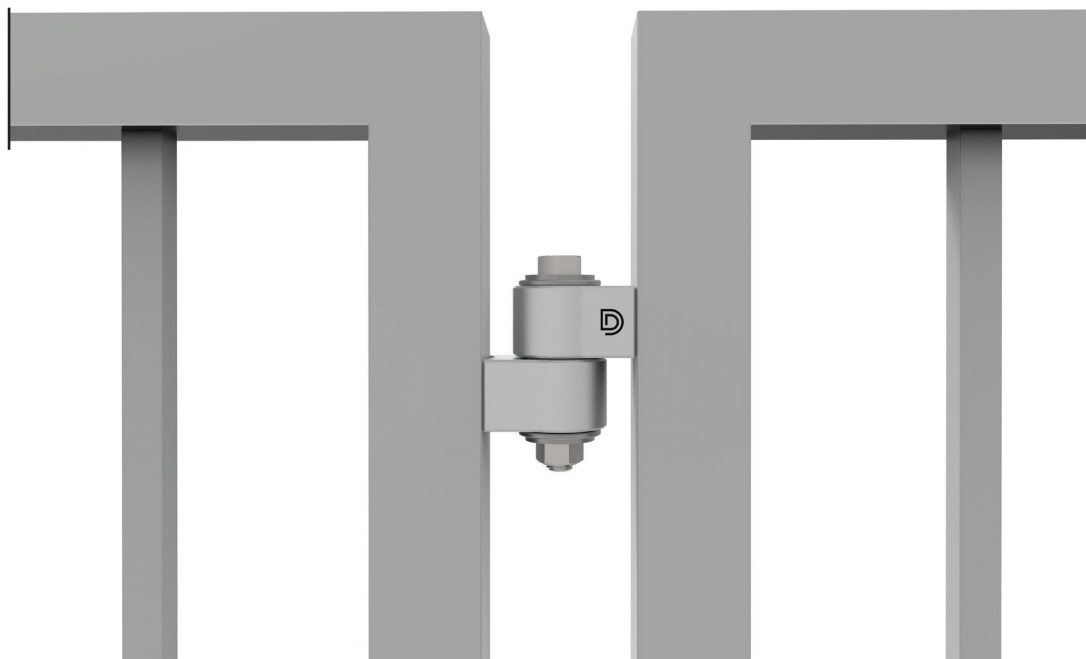

MKT-134-0119